

Standard Wiring Example of Control Circuit

● Wiring example at each control mode

● CN X5 Wiring example at torque control mode

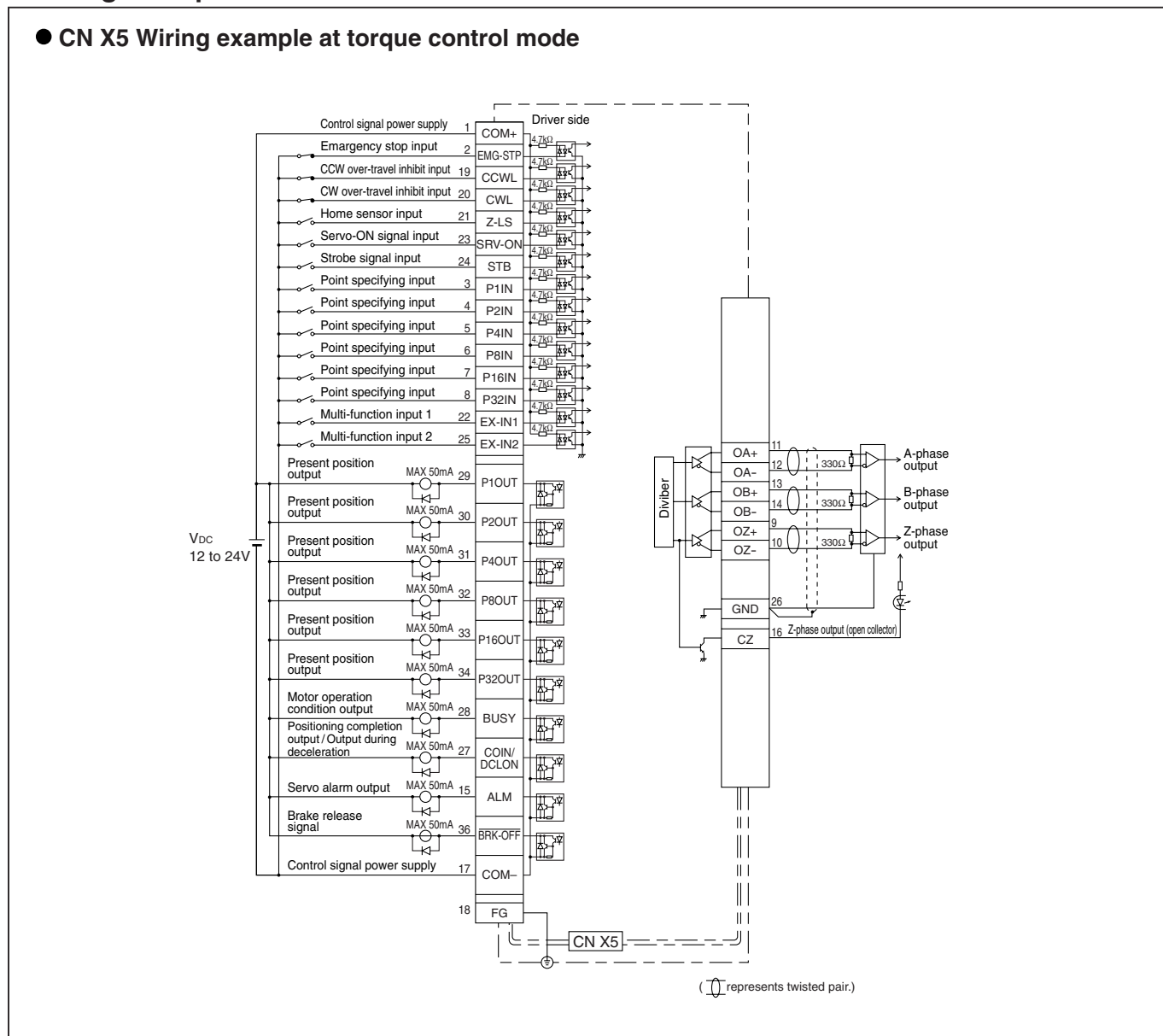

Table of Applicable Motors

Driver		Motor series							
Frame symbol	Part No.	MAMA	MSMD	MQMA	MSMA	MDMA	MGMA	MFMA	MHMA
A-frame	MADDT1105P		MSMD5AZ***						
	MADDT1107P		MSMD011***	MQMA011***					
	MADDT1205P		MSMD5AZ***	MQMA012***					
	MADDT1207P	MAMA012***	MSMD022***	MQMA022***					
B-frame	MBDDT2110P		MSMD021***	MQMA021***					
	MBDDT2210P	MAMA022***	MSMD042***	MQMA042***					
C-frame	MCDDT3120P		MSMD041***	MQMA041***					
	MCDDT3520P	MAMA042***	MSMD082***					MFMA042***	MHMA052***
D-frame	MDDDT3530P					MDMA102***			MHMA102***
	MDDDT5540P	MAMA082***			MSMA102*** MSMA152***	MDMA152***	MGMA092***	MFMA152***	MHMA152***
E-frame	MEDDT7364P				MSMA202***	MDMA202***		MFMA252***	MHMA202***
	MFDDT390P				MSMA302***	MDMA302***	MGMA202***		MHMA302***
F-frame	MFDDT3A2P				MSMA402*** MSMA502***	MDMA402*** MDMA502***	MGMA302*** MGMA452***	MFMA452***	MHMA402*** MHMA502***

Refer to page, A4-37, Table of Part Numbers and Options as well.